

INTEGRATED NETWORK ANALYSER MODULE FOR MICROWAVE MOISTURE SENSORS

*J. Sachs**; *P. Peyerl***

*Technische Universität Ilmenau

**MEODAT GmbH, Ilmenau

ABSTRACT. A new ultra wideband measurement principle will be introduced. It is able to replace network analyser or TDR systems in low cost microwave sensors such as moisture sensors. The basic idea is to apply MLBS-signals instead of sine wave or pulse signals as in the classical approaches. This greatly simplifies the structure of the measurement system and permits the use of digital circuit concepts which are easily to integrated. To prove the functioning of the new conception and to investigate the performance, a 5 GHz-measurement head was implemented. It is build from an customer integrated SiGe-RF-frontend and a digital unit manufactured in classical multi-layer PCB-technology.

Keywords: Ultra Wideband, Network Analyser, TDR, SiGe-Technology

1. INTRODUCTION

It is well known that the permittivity and the loss tangent of a material mixture depends from its individual components, its adhesive or chemical bond and its geometrical structure. This behaviour may be observed in solid or bulk materials as well as in liquids and biological material. Thus the idea to determine the constitution of materials from electrical measurements is obviously. The advantages of these methods are their simplicity of use, their robustness and the continuous and fast measurement procedure. These are features very important for industrial volume applications. Unfortunately the method implicates an inverse problem, which is generally ill-posed and ambiguous.

The only way to restrict or to exclude ambiguousness is to concentrate to a certain class of material mixtures and to gather as much as possible (electrical) information from the target material. The restriction to specific substances and a specific problem respectively is generally given in case of moisture measurements, since the basic substances are known. Furthermore the permittivity of water is quite different from that of the most substances. Thus the conditions to solve "the moisture problem" by electrical measurements seem to be not so bad. However the electrical properties of a material depend not only from the water content but also from the salt content, the material density, the gravel size etc. as well as the temperature and probably also from the exposure time of moisture. Additionally the moisture distribution within a material under test may be inhomogeneous so that also the moisture profile can be of interest.

The remaining option to separate all these effects is to determine the electrical properties of the target material at a known temperature for a very large bandwidth hoping that the different effects distinguish in their frequency behaviour (and that these distinctions can correctly be interpreted). But most off the current moisture sensors are strictly limited in the sensing bandwidth giving partially away the capability of the measurement method. Two reasons are responsible for the limitation to narrow band systems.

- One point is to be found on a legal level, since it is only allowed to transmit electromagnetic energy within certain fixed and strictly limited frequency bands. However the ultra

wideband (UWB) technology will find more and more industrial applications so that the FCC (Federal Communication Commission of the US) and the ERO (European Radio-communication Office) are working on new rules allowing UWB systems. It should be noted, that the radiation of a UWB system is spread over a large bandwidth thus the spectral density of perturbations is often less than the interference provoked by a common PC.

- The other point is caused by technical difficulties. "Although there has been some commercial application of these (ultra wideband) measurements for material sensing, there has been no significant effort to produce low cost multi-frequency sensors for volume applications" [1]

This article will mainly address to the second point – the introduction of a completely digitised UWB-measurement system, which is able to replace expensive and voluminous network analysers or TDR systems in moisture sensors. The first chapter will summarise the problem of microwave moisture measurement from a very global stand point of system theory in order to be able to compare the different measurement principles. Then a new ultra wideband measurement principle will be explained as well as some experimental results will be shown. These results shall demonstrate the basic behaviour of the pure measurement system independent from a certain kind of applicator. Concerning different types of applicators the reader is conducted to [2].

2. THE MOISTURE SENSOR AS LTI-SYSTEM

There are a lot of different measurement arrangements and applicators using guided or free waves. But in all cases, the microwave moisture sensors may be considered as a linear time invariant (LTI) one-, two- or n-port. Figure 1 illustrates two fundamental two-port arrangements.

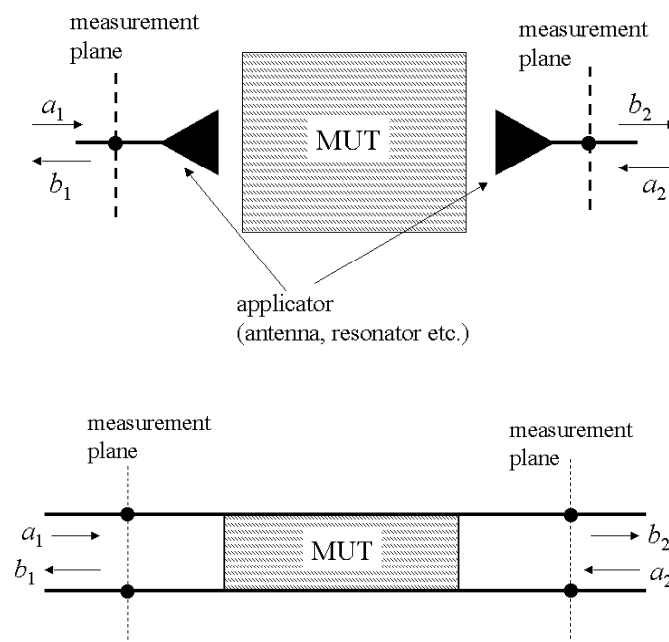

Figure 1 Schematic arrangements of microwave moisture sensors forming an electrical two port. The upper configuration uses free electromagnetic waves. The lower one applies guided waves. Wave guide applicators either enclose the material under test (MUT) – as shown in the example - or the MUT surround the wave guide (the fork probe for example).

In both cases demonstrated in Figure 1, the actual measurement signals refer to wave guide modes at the locations of the measurement planes. As usual in microwave technique, they are expressed by the normalised waves a and b .

If the applicators and the MUT are showing a linear behaviour – which generally can be supposed – the relations between the different waves occurring at the measurement planes is forming a system of linear equations. It may be expressed as follows:

$$\underline{\mathbf{b}}(f) = \underline{\mathbf{S}}(f) \cdot \underline{\mathbf{a}}(f) \quad \text{for the frequency domain} \quad (1)$$

$$\mathbf{b}(t) = \mathbf{S}(t) * \mathbf{a}(t) \quad \text{for the time domain} \quad (2)$$

In the case of a n -port moisture sensor, the column vector \mathbf{a} contains the n incoming waves $a_1 \dots a_n$, the column vector \mathbf{b} contains all n outgoing waves $b_1 \dots b_n$ and the n by n system matrix \mathbf{S} summarises all scattering parameters $S_{11} \dots S_{nn}$ characterising the system under test. For a one port sensor (resonator, fork probe, single antenna, open line etc.) the matrix relations (1) and (2) degenerate to a simple scalar equation describing the reflection coefficient respectively the impedance of the probe. The frequency domain representation refers to complex valued spectral quantities $\underline{\mathbf{a}}(f)$, $\underline{\mathbf{b}}(f)$ respectively a matrix $\underline{\mathbf{S}}(f)$ of frequency responses functions (FRF) and a simple matrix product whereas the time domain representation includes only real valued signals $\mathbf{a}(t)$, $\mathbf{b}(t)$ respectively a matrix $\mathbf{S}(t)$ of impulse responses functions (IRF) and an unpleasant convolution product $*$.

The scattering matrix expressed either in the frequency $\underline{\mathbf{S}}(f)$ or time domain $\mathbf{S}(t)$ includes all information of the MUT (embedded by the behaviour of the applicators) which are accessible by an electrical measurement. Finally, it is the work of the user to extract the wanted information - i.e. the moisture content - from the measurements by an appropriate model. From the theoretical view point, there is no difference concerning the information content of $\underline{\mathbf{S}}(f)$ or $\mathbf{S}(t)$ since they may be converted mutually by the Fourier transform. The classical device for determining the system behaviour in the frequency domain $\underline{\mathbf{S}}(f)$ is the network analyser. Whereas the time domain behaviour $\mathbf{S}(t)$ is measured by the TDR (Time Domain Reflectometer)¹. Both classical approaches are fundamentally able to represent the characteristic functions $\underline{\mathbf{S}}(f)$ respectively $\mathbf{S}(t)$ immediately from the captured signals without need of any additional signal processing. This was inevitable at the past where digital signal processing was not available in measurement devices. Though the measurement systems were dependent on specific test signals like frequency stepped/swept sine waves, short impulses or sharp steps having remarkable consequences with respect to system costs, flexibility, stability, bandwidth and others (see [3] for more details). In order to reduce costs for simple sensor applications, therefore one has to be content oneself with reduced system parameters in expense of reduced information worthiness of the results.

In the last years, the situation has drastically changed. Practically all measurement equipment contains digital processing systems. But with respect to the basic measurement philosophy the situation has been the same – one still applies sine waves or impulses in the microwave measurement technology. Thus the basic problems with that principles were not overcome. Fortunately, the theory of LTI-systems don't insist on sine waves or pulses for the determination of the system behaviour corresponding to equations (1) or (2). It only requires wideband signals

¹ Correctly spoken, the TDR determines usually the step response $\int \mathbf{S}(t) dt$ of a system since step signals stimulate the objects instead of short impulses.

what ever their actual shape is. This realisation has a lot of effects on the design of a measurement principle, since one is free in the selection of an appropriate test signal. However, the human being isn't still able to interpret the captured signals now thus a signal processing is inevitable. The corresponding hardware don't provoke additional costs, since digital subsystems are always included in modern sensor systems.

3. THE MLBS-PRINCIPLE

The technical implementation of a low cost measurement system for volume applications requires among other things above all a largely integrated RF-part which is based on a simple and stable circuit conception. Consequently, high peak power signals and sweep processes should be avoided. That means, that a wideband signal which covers the whole spectrum of interest having a low crest factor has to be provided. A low crest factor signal possesses a high average power at relative low peak power. In the ideal case - for a crest factor of one - peak and average power of a signal are identical. Thus the electronic components which generate respectively capture such signals are only scarcely stressed. This promotes a circuit integration and the handling of high bandwidth signals.

The maximum length binary sequence (MLBS) is a signal which meets these requirements. It is a special kind of a binary random code. Its time shape, auto correlation function and spectrum are indicated in Figure 2.

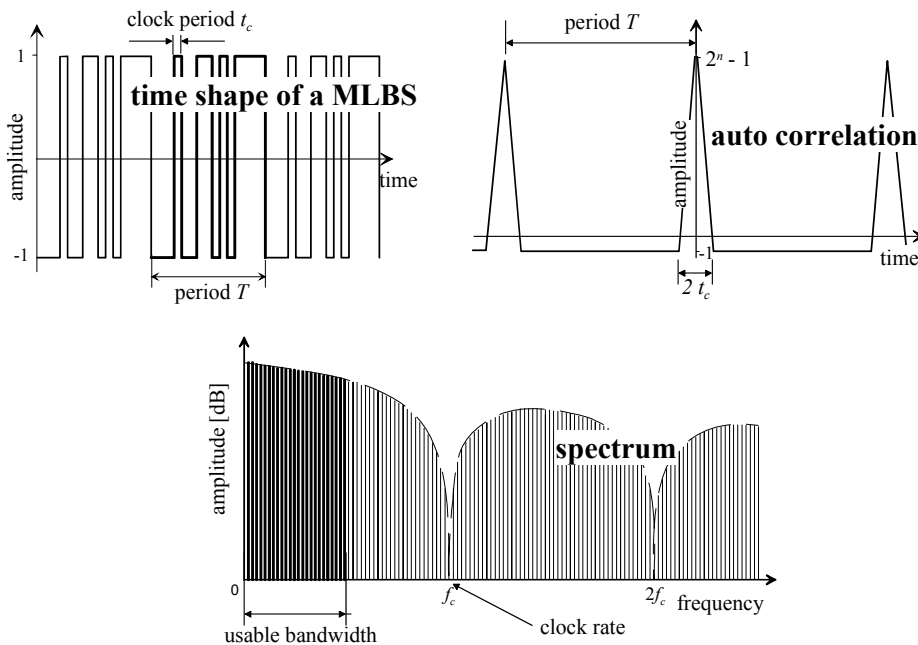

Figure 2 Time shape, auto correlation function and spectrum of a MLBS. For a better graphical representation the shown spectrum applies to a MLBS of higher order than used in the upper diagrams.

A MLBS of order n may be generated by a n -stage shift register using an appropriate feedback. The MLBS period length is $T = (2^n - 1)t_c$, where t_c is the period of the RF-clock pushing the shift register. The MLBS is a periodic signal thus the undersampling principle may be applied for signal capturing. This greatly simplifies the electronic circuitry especially if the equivalent sampling rate corresponds to the clock rate $f_c = 1/t_c$ of the RF-clock. The spectrum

of the MLBS is a comb spectrum enveloped by a sinc²-function having $2^n - 1$ spectral lines from dc to the first zero. However only the half number of spectral lines is usable for measurement purposes in order to avoid aliasing effects. Since half of the spectral energy is yet concentrated in this part, it is not a big loss on performance. Much more important concerning the simplicity of system structure is the fact, that the equivalent sampling rate is fixed to f_c , which may simply be achieved by introducing a binary divider between RF-clock and signal capturing (T&H and ADC). The reader is referred to [3] and [4] for more details on the sampling control. The actual sampling rate can be chosen quite low, so that low cost ADC's may be applied for signal gathering, supposing that a fast Track and Hold-circuit (T&H) holds the signal level during the acquisition.

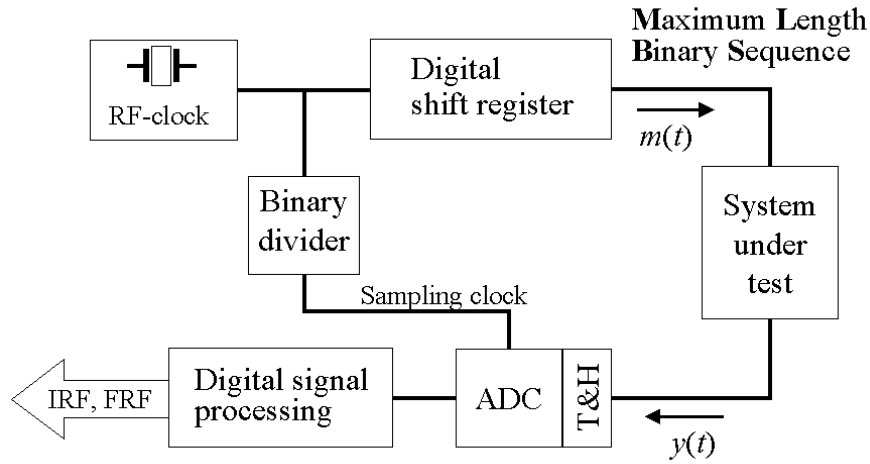

Figure 3 Elementary structure of the MLBS measurement head

Figure 3 summarises the basic system structure. As to be seen the hardware structure is very easy and the different subsystems are based mainly on digital circuits. Usually the RF-clock, the shift register, the binary divider and the T&H-circuit are implemented in an integrated circuit if a bandwidth of more than 500 MHz ... 1 GHz are required.

Considering the simple case of a one port sensor and supposing that the signal $m(t)$ corresponds to the injected wave $a(t)$ as well as $y(t)$ corresponds to the reflected wave $b(t)$, the reflection coefficient of the sensor port is given by²:

$$\underline{S}_{11}(f) = \frac{\text{FFT}\{y(t)\}}{\text{FFT}\{m(t)\}} \text{ for the frequency domain} \quad (3)$$

respectively for time domain:

$$S_{11}(t) \equiv y(t) * m(-t) = \psi_{ym}(t) = \text{FHT}\{y(t)\} \quad (4)$$

since

$$m(t) * m(-t) = \psi_{mm}(t) \equiv \delta(t)$$

² In order to avoid aliasing we will suppose, that the bandwidth of $y(t)$ is smaller than $f_c/2$.

ment signal in cause of their mutual delay. This method requires an ultra wideband system and is not suitable for the narrow band configurations. Other conceptions include directional couplers to separate the waves a and b . They should be preferred in narrow band systems.

4. EXPERIMENTAL RESULTS

The implemented measurement head consists of two parts - a digital part and the RF-frontend.

The digital respectively processing part contains two acquisition channels build from two 40 MHz-Video-ADCs which are followed by a FPGA and a DSP. The FPGA is responsible for the fast signal pre-processing whereas the DSP serves as main processor. The whole system is assembled on a multi layer PCB and may also act in a stand alone mode having a bandwidth from DC to 60 MHz in the base band variant (see Figure 3) respectively of 120 MHz in the modified version corresponding to Figure 5. Three interfaces for data exchange are available (serial, LVDS and an integrated Web-server), in which the LVDS-interface was intended for a transfer rate of up to 6 000 IRFs respectively FRFs per second. Certainly this data rate is out of interest for many moisture measurement applications. But the investigation of the moisture content in fast moving bulk material on a conveyor belt may absolutely profit from a high measurement speed since irregularities provoked by the transport process can be eliminated.

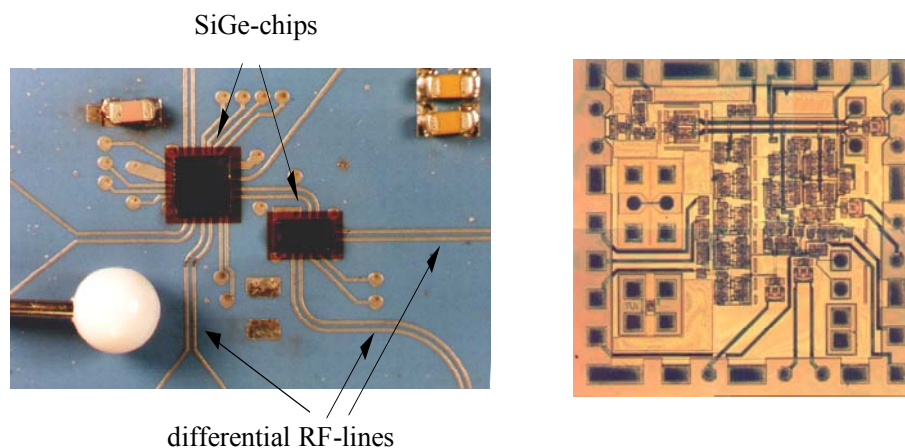

Figure 6 left: Photo of the RF-frontend. A pin head is shown for comparison.
right: View of one of the SiGe-chips. Its size is $2 \times 2 \text{ mm}^2$.

If the required bandwidth exceeds 60 MHz, a RF-frontend has to connect in front of the digital part. A RF-frontend contains one output channel, one input channel and a clock recovery stage for cascading several systems in multi-channel arrangements. Depending from the clock rate, this RF-frontend is able to provide a usable bandwidth from near DC to 5 GHz. It is build from two SiGe-chips mounted on four layer LTCC (low temperature co-fired ceramic) (see also [5] and [6]). Both are sophisticated low cost technologies (a corresponding number of units supposed) which are strongly pushed by the current developments in the mobile communication. The SiGe-chips include the shift register, the programmable binary divider, the T&H-circuit and a synchronisation circuit. Their maximum clock rate ranges in the region of 11 ... 12 GHz. In the present case, the shift register has nine stages, which results in a 511 point IRF respectively a 255 point complex valued FRF. Figure 6 is showing the heard of the RF-frontend. As indicated, all RF-ports/lines are symmetrically designed. This reduces electromagnetic interference and avoids BALUNs which are difficult to handle in UWB applications. Nevertheless an unbalanced operation mode is also permitted by matching (50Ω) one of the two lines.

A section of the time shape of the actual stimulus signal respectively of its spectrum is presented in Figure 7. The rise and fall time of the individual impulses of the MLBS is about 40 ps. Spectral components could be observed up to 26 GHz. Obviously some differences appear concerning the ideal case demonstrated in Figure 2 caused by the actual behaviour of the circuits. But these deviations may be calibrated out in cause of the excellent stability of the system. An overall jitter less than 140 fs could be detected. The width of the system impulse response is about 170 ps and the maximum dynamic range is in the order of 100 dB at a stimulus level of 0 dBm.

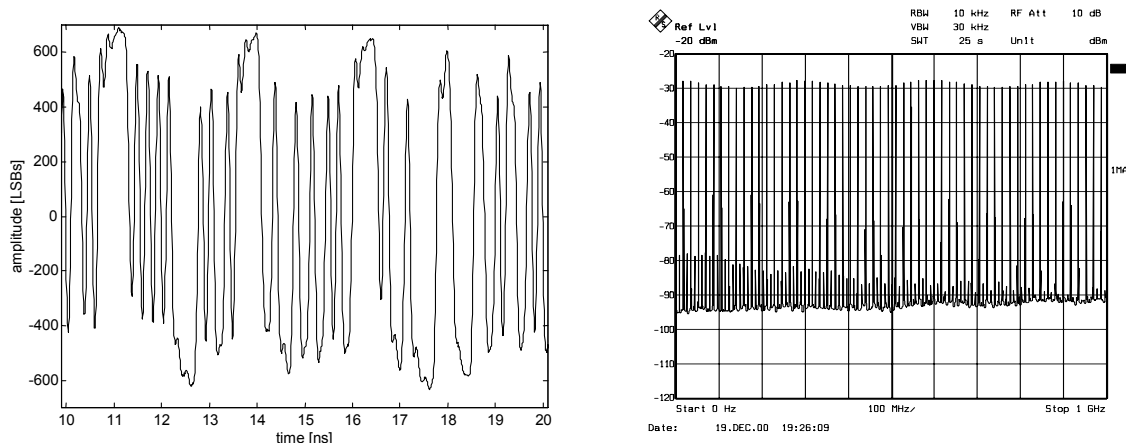

Figure 7 A 10-ns section of the actual stimulation signal (left) and the lower part (up to 1 GHz) of its spectrum (right).

5. CONCLUSION

A new ultra wideband measurement principle for the microwave range was shown. The simplicity and flexibility of the system design favours it for low cost microwave sensors - like moisture sensors - with large scale applications. On the other hand, the required technological implementation supposes high volume applications since otherwise the costs per unit will be too high. The symmetrical circuit conception offers a high resistance against electromagnetic interference as well as a high flexibility in connection of different applicators. Promoted by the newest 0,35 mm-SiGe:C BiCMOS technology, it may be expected that single-chip-solutions will be available in the future which include both RF- and digital part and operating at clock frequencies up to 20 GHz .

REFERENCES

- [1] T. Warnagiris: Liquid Sensing at Radio Frequencies. Microwave Journal, vol. 43 (2000), No.9. p. 140
- [2] A. Göller: Mikrowellen-Feuchtemessung – Auswahl geeigneter Applikatoren. 9. Feuchttagung, Proceeding p. 131, Weimar 1997, Germany
- [3] J. Sachs, P. Peyerl, M. Roßberg, P. Rauschenbach, J. Friedrich: Ultra-Wideband Principles for Surface Penetrating Radar. EUROEM 2000. Edinburgh 2000, UK
- [4] J. Sachs, P. Peyerl, M. Roßberg: A new UWB-Principle for Sensor-Array Application. IMTC/99, Venice 1999, Italy
- [5] M. Roßberg, J. Sachs, P. Rauschenbach, P. Peyerl, K. Pressel, W. Winkler, D. Knoll: 11 GHz SiGe Circuits for Ultra Wideband Radar. IEEE Bipolar/BiCMOS Circuits and Technology Meeting, Minneapolis, USA, 2000
- [6] J. Sachs, M. Roßberg, P. Rauschenbach, P. Peyerl, J. Friedrich: Integrated UWB Radar Circuit for Base Band Applications from DC to 5 GHz. German Radar Symposium, GRS 2000, Berlin, Germany 2000