

M-Sequence Ultra-Wideband-Radar: State of Development and Applications

J. Sachs

Technische Universität Ilmenau, Ilmenau, Germany
(phone: +49-3677-69-2623, fax: +49-3677-69-1113, e-mail: juergen.sachs@tu-ilmenau.de)

P. Peyerl

MEODAT GmbH, Ilmenau, Germany (pey@meodat.com)

R. Zetik

Technische Universität Ilmenau, Ilmenau, Germany (rudolf.zetik@e-technik.tu-ilmenau.de)

S. Crabbe

Germany (stephen.crabbe@t-online.de)

Abstract— The UWB approach is a promising and challenging technique for a great deal of sensor tasks for volume applications with economical and social impact. Impulse and swept sine waves are the classical methods to cover a wide spectral band. The M-Sequence technique joins the merits of both principles without their drawbacks. The M-Sequence technique provides stable UWB-data at reasonable costs and device dimensions due to its simplicity and the absence of bulky off-chip components which are amenable to monolithic integration.

I. INTRODUCTION

The article will deal with an universal Ultra-Wideband-(UWB)-Principle for Radar sensor applications, its basic functioning and some applications. The task of the UWB-electronics is to stimulate the scenario under test and to capture the scattered waves from which the behaviour of the test objects is derived.

The UWB-Technique is a promising and strongly evolving technique for high resolution short range remote sensing and impedance spectroscopy for material characterisation. Regardless of the restrictions concerning the emission of electromagnetic fields (see [1], [2]), a favourable frequency range for many applications is to be found below 1 to 20 GHz. Electromagnetic waves of such frequencies are able to penetrate into many materials. A large bandwidth (fractional bandwidth beyond 20 %) i.e. a high spatial resolution, provides the technical basis for a great deal of significant sensor applications for monitoring, testing and controlling of events and processes in industry (food industry, construction industry etc.), medicine, environmental protection, security screening, traffic control and others. In addition to the potentially high spatial resolution of UWB-sensors due to their large bandwidth, they also provide good recognition capabilities by provoking “telltale” Eigen-modes of the objects under investigation.

Applications such as distance monitoring for example which do not require wave penetration into materials are of course not restricted to frequencies below 20 GHz. To conform with the UWB-definition, the absolute bandwidth

in such cases must however exceed 500 MHz.

In order to understand the requirements of modern UWB-electronics, one has to consider the frame in which it is embedded. To an increasing extent, UWB sensor applications tend to analyse strongly inhomogeneous structures and respectively to search for hidden objects in such environments. To solve such problems, one is required to capture as much information as possible from the scenario under test by the sensor arrangement and to extract the wanted information from the gathered data volume. It is known that the Green’s Tensor of a sector of space covers all electrical accessible information concerning its geometrical structure and composition. Consequently, the more complex a measurement task is, the more complete the components of the Green’s Tensor has to be measured and the more complicated the inversion algorithms will be which shall finally lead to the information looked for. The consequence is that UWB-arrays, even polarimetric ones, are increasingly in use and that the effort in data processing is rapidly growing. Concerning the last point, it shall be underlined that UWB-arrays provide an enormous amount of data which in the extreme case a single bit after processing determines whether there is a specific target or not. Processing techniques which address such problems are called “data mining”. This means the data-driven discovery and modelling of hidden patterns in large volumes of data.

Translated to UWB-electronics, the above mentioned trends result in the following general basic demands:

- A high bandwidth at (mostly but not exclusively) low central frequencies is the key parameter which has given the name to the technique.
- Array operations suppose numerous transmit and receive channels. In order to limit the measurement time the operational speed has to be fast enough. Usually the receive channels should work in parallel.
- A sophisticated software as required in UWB-applications needs high quality data in the sense of low random noise, drift and systematic errors.
- The UWB-Technique is being commercialised. This implies further strong elementary demands on costs, power consumption, weight, size and robustness of the devices.

In addition to these demands, the error avoidance and error handling by the UWB-electronics is likely to be one of the most exciting issues for its practical application at large scale. UWB-systems are sensible to a great deal of different errors by their nature. It is mainly due to the large bandwidth of the systems which implies random noise and jitter. Furthermore, it makes them sensible to time drift and systematic error (frequency dependent sensibility, cross-talk, mismatch etc.).

In what follows, the UWB-principle available will be shortly assessed with regards to the criterions mentioned above. The ultra-wideband M-sequence principle will be illustrated and some current application activities will be mentioned.

II. UWB-PRINCIPLES

There are two classical UWB-approaches applied for decades – the sine wave technique and the impulse technique.

A. Sine Wave Technique

A sine wave which stimulates the test objects is slowly swept or stepped over the frequency band of interest. Usually a heterodyne receiver based on fundamental or harmonic mixing captures the scattered fields and provides by quadrature demodulation the complex transfer characteristic of the sensor arrangement at every frequency point. This principle is certainly the most sensible method due to the excellent noise rejection and suppression of intermodulation products by the narrow band IF filters. The low crest factor of the sine waves promotes the handling of signals rich in energy resulting in large SINAD-values. Furthermore, highly sophisticated synthesiser sources provide for stable operational conditions so that effective methods can be applied to remove systematic errors. Vector network analysers and stepped frequency radars are typical devices applying this approach. However these devices are very complex and difficult to integrate into monolithic semiconductor circuits through which costs, power consumption, weight etc. suffer. It is therefore hard to believe that this technique will find access to a large scale UWB-market. Admittedly, there exists a low cost version employing the homodyne concept – the FMCW principle – but it only provides the real part of the sensor transfer function (thus for most applications a significant part of information is missing) and additional effort is needed to stabilise and linearise the VCO.

It should be mentioned here that in the exact sense the sine wave approach is actually excluded from the UWB-technique since its definition refers to a wide *instantaneous* spectrum. Nevertheless, from the viewpoint of the sensor applications (but not from the view point of interference to communication systems) the stepped sine technique can rank with the UWB-methods. There is no fundamental difference if the full spectrum of the stimulus is provided instantaneously or successively as long as the test objects behave linear and time invariant. In case of a moving scenario, time invariance may be approximately supposed as long as relation (1) holds (note that (1) is a general relation

which is not restricted to sine wave methods).

$$4T_{obs} |v_{max}| < \frac{c}{B} \quad (1)$$

Herein T_{obs} refers to the time needed to gather a complete data set over the whole frequency band of interest (and all measurement channels if arrays are applied), v_{max} is the maximum velocity appearing in the scenario under test, c is the speed of light and B the width of the frequency band. Concerning the maximum target speed and respectively the speed of sensor motion, the sine wave approach is however limited compared with other principles. As most of the time is uselessly passing by waiting for the settling of the narrow band filters within the receiver and the synthesiser. Furthermore, for array applications, economical restrictions usually forbid the employment of numerous receivers in parallel which additionally increase the observation time T_{obs} .

B. Impulse Technique

Currently, the most popular UWB-approach is certainly the impulse technique. A short pulse of adequate energy stimulates the scenario under test and the scattered signal is gathered by a scope. With the exception of some exotic test arrangements which use real time DSO's, the usual method for data capturing is (sequential) under sampling since the hardware is less expensive. Data gathering by under sampling requires repetitive stimulation of the objects since only one data sample is captured at each pulse. Clearly, the measurement time T_{obs} will be expanded by that approach, but it can be accepted in many cases because the propagation speed of the sounding waves is orders beyond a typical target speed. It can be generally stated that measurement approaches which are based on signals having a large instantaneous bandwidth suffer less due to settling of the measurement system than the sine wave technique. Impulse systems with moderate parameters have low power consumption and can be manufactured at low costs.

The bottleneck of the approach is the handling of high voltage signals and the sampling time control. In order to gain an acceptable SNR-value a reasonable amount of the stimulation energy must be concentrated into a short pulse. The larger the bandwidth which is required the more problems it causes. The sampling time control is performed by a threshold triggering which releases the sampling event. For that purpose a linear ramp is generated synchronously to the stimulus signal. Its duration is identical to the time segment which shall be recorded. The sampling point is successively shifted over the signal by moving a threshold over this ramp. However, any inadequacy of the ramp and the threshold voltage (noise, offset drift, non-linear rise) will affect the data gathering by jitter, time drift and non-equidistant sampling. The weaker the rise of the ramp is the worse the jitter and drift. The suppression of these effects requires sophisticated hardware and additional control loops. This complicates the devices and aggravates large scale applications which requires high quality data for signal processing.

C. M-Sequence Technique

The M-Sequence technique is closely related to the impulse technique but it joins the advantage of that technique (simple layout, high measurement speed) with those of the sine wave approach (high stability, low crest factor signals). It also applies periodic signals having a large instantaneous bandwidth and the data are captured by under sampling in order to reduce hardware costs and data throughput. However, there are two decisive differences compared to the impulse technique. They concern the type of stimulus signal and the method to control the sampling instant.

Fig. 1 illustrates the fundamental approach. A fast digital shift-register with an appropriate feedback provides a M-Sequence having a bandwidth up to several GHz. This signal stimulates the device under test (DUT). In contrast to the classical impulse excitation, the M-Sequence distributes its energy over the complete measurement time. Thus, the signal amplitude may be comparatively low even if a large amount of power is required in order to gain a certain SNR. Signals with low amplitudes are easy to handle and they promote a monolithic circuit integration resulting in an improved RF behaviour. As in the pulse method the wideband measurement signal is captured by under sampling but the sampling is controlled by a binary divider. This is a very effective method since drift and jitter are largely suppressed due to the steep flanks of the divider and furthermore it avoids non-linear sample spacing completely. After digitising, the data is processed in an appropriate manner. Usually, the sampling rate is chosen to be beyond the processing throughput in order to obtain the opportunity to suppress random noise by synchronous averaging.

The approach for the sampling control using the binary divider is based on the following idea. Supposing the measurement task requires a sampling rate of f_s in order to respect the Nyquist theorem, in the case of real time sampling this would give $N = f_s/f_0$ samples per period of the measurement signal, if f_0 is the repetition rate of the stimulus. However it can also be shown, that corresponding to (2) any other sampling rate f_{sa} being quite lower than f_s may be used to collect the same data samples. Though N and the under sampling factor u_{sf} must not have a common divider. By this procedure, the natural order of samples may be jumbled but they can be re-established.

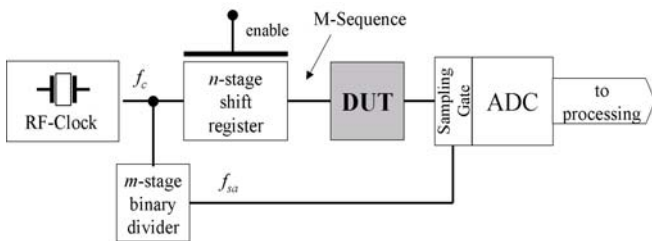

Fig. 1. Basic structure of a M-Sequence UWB-system. The shift register provides the wideband stimulus signal (M-Sequence). Its clock rate finally determines the bandwidth of the measurement system. The data samples are captured by an under sampling procedure, which is controlled by a binary divider. The impulse response function of the DUT is received by subjecting the measurement data to a digital impulse compression (usually undertaken by the Fast Hadamard Transform). If the frequency behaviour of the DUT is of interest, the data has to be processed by the Fourier Transform.

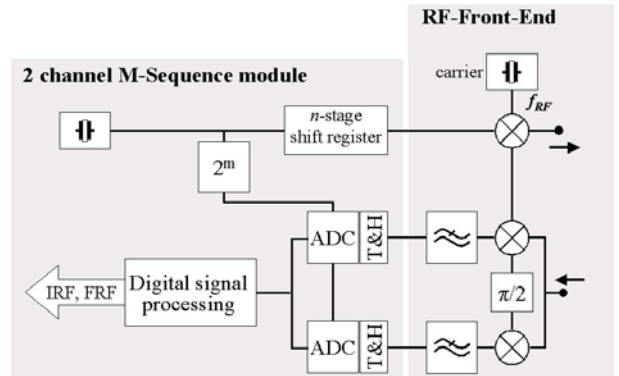

Fig. 2. Example of an MSCW-Radar. The schematics shown represent the basic structure of a homodyne coherent MSCW-Radar. The M-Sequence modulates the carrier for example by phase shift keying, this signal acts as stimulus. The receive signal is quadrature demodulated and digitised by the above mentioned approach. In contrast to the FMCW-principle where only the real part of the receive signal is captured, this method provides the full information i.e. the complex base band signal.

$$u_{sf} = \frac{f_s}{f_{sa}} = N \cdot \frac{f_0}{f_{sa}} \quad (u_{sf}, N \text{ integer numbers}) \quad (2)$$

Furthermore, the envelope of the power spectrum of the M-Sequence has a sinc²-shape with zeros at multiple of the clock rate f_c . Thus, roughly 80 % of the signal energy is concentrated to the frequency band below $f_c/2$. That means one can cut the frequency band of interest at $f_c/2$ without dramatic loss in performance. In order to respect the Nyquist theorem, this again leads to an (equivalent) sampling rate f_s which is equal to the clock rate $f_s = f_c$ i.e. one sample per chip of the M-Sequence. The period of an M-Sequence consists of $N = 2^n - 1$ chips in which n is the length of the shift register. Since any number N of such kind can never be divided by 2 an arbitrary binary divider can be used to provide the sampling clock (refer to (2)). As already mentioned above, the system stability greatly benefits from the steep flanks of the divider as well as the accuracy of the temporal sample spacing. The divider only releases a sampling event after it has run completely through all its internal states. Furthermore, this sampling approach opens up the opportunity to adapt the speed of data capturing to the actual needs of the measurement task. In high speed applications, short binary dividers are used so that more

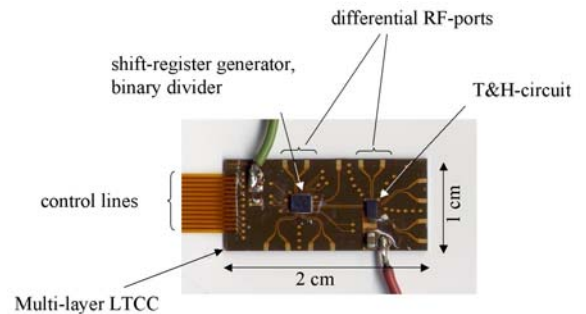
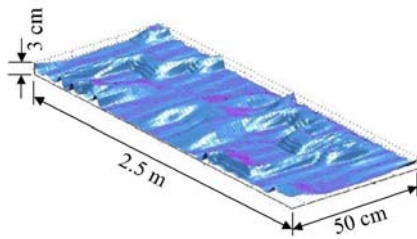

Fig. 3. Heart of the RF-part of the M-Sequence radar. Two customer chips are mounted on a multi-layer LTCC (low temperature co-fired ceramic) for wiring. These are the sampling gate (operating in the T&H-mode) and the shift-register generator joint with the binary divider. Note that only differential RF-ports are used which gives a high flexibility in connecting symmetrical or unsymmetrical devices e.g. antennas.



Radar head including the RF-electronics, the fast digital pre-processing and the antenna array.



Surface profile of a test lane gained by the radar

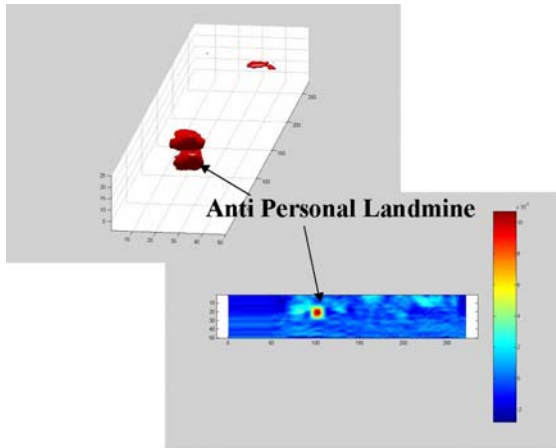

Radar images of a buried land mine after processing (Courtesy Vrije Universiteit Brussel)

Fig. 4. The DEMINE Radar

than one data sample per period can be captured (an approach which is not applicable in the case of sequential sampling or for the impulse technique). The limiting factor concerning the measurement speed is finally the digital data processing which has to follow the data stream. Low speed applications consequently use long binary dividers resulting in reduced requirements concerning the processing speed. See [3] - [6] for more information on the M-Sequence principle.

The M-Sequence approach enables in a simple way the ability to build fast operating multi-channel arrangements as used in UWB-arrays [3]. Every measurement channel is equipped with its own signal source (shift register) and respectively receiver circuit (Track & Hold (T&H) or Sample & Hold (S&H) plus ADC) since this is a great deal less expensive than the use of RF-switches. This opens up the opportunity to run all receivers in parallel from which the overall measurement speed greatly profits (but the data processing suffers). Since the transmit signals of the

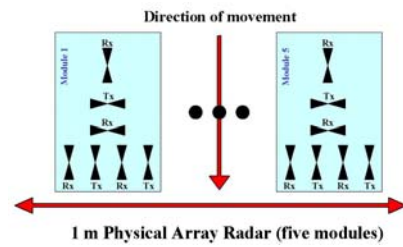

Arrangement of the antennas. The whole DEMAND Radar covers five modules including seven antennas each.



One complete module Radar module: below – the antenna array (courtesy I.D.S. Ingegneria dei Sistemi S.p.A, Pisa, Italy); middle – RF-electronics (3 transmitters and 4 receivers); top – digital pre-processing, power supply, data interface, operational control

Fig. 5. The DEMAND Radar

different transmitters in an array are not mutually orthogonal, only one transmitter may be active. Thus, the different transmit channels must be activated in turn which can be simply controlled by enabling the shift register with a TTL-signal.

Finally, it shall be mentioned, that the large bandwidth of the M-Sequence module may be shifted to an arbitrary frequency plane by joining it with a homodyne or heterodyne RF-front. Fig. 2 shows one of the different possibilities. In imitation of the FMCW-term, we called it MSCW-Radar - Maximum Sequence (modulated) Continuous Wave-Radar.

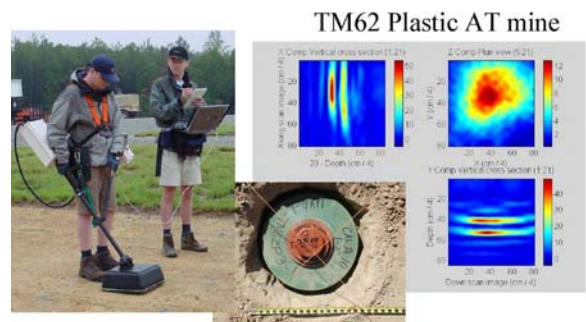

The Radar in use and typical radar images from buried objects (courtesy QinetiQ, UK).

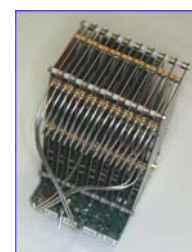

The 9 Tx/Rx - Radar electronics

Fig. 6. The QinetiQ Radar

III. STATE OF DEVELOPMENT, EXAMPLES OF APPLICATION

Several UWB-systems based on the M-Sequence approach have been implemented and tested. The key components of the radar electronics cover:

- A commercial DRO which provides the stable RF-master clock,
- Customer made integrated RF-circuits manufactured in SiGe-technology,
- Multiplayer RF-PCBs and LTCC (low temperature co-fired ceramics) boards (see Fig. 3), and
- Fitted digital hardware for high rate digitising and averaging, impulse compression, data transfer and management of the measurement procedure.

Typical RF-clock rates of the shift register range in the 7 to 10 GHz area depending upon the parameters of the semiconductor technology resulting in an usable bandwidth in the order of approximately 3 to 4 GHz. Through newer SiGe-technologies, the maximum clock rate could be improved to about 15 GHz. 20 GHz of clock rate and more are envisaged for the future.

The following examples of applications of the M-Sequence principle refer mainly to high resolution Surface Penetrating Radar devices for landmine detection. Some further examples provide some hints on other potential applications.

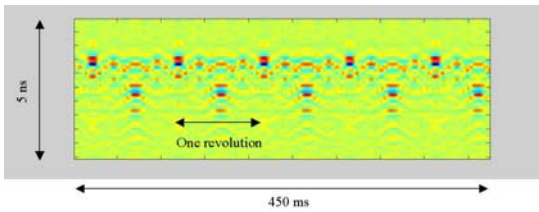

Radargram showing a part of the gathered data after background subtraction. Note that the indicated time segment covers about 15 000 impulse response functions. One complete impulse response consists of 511 points and it is expanded over 50 ns.

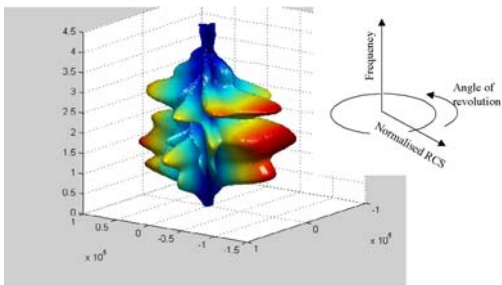
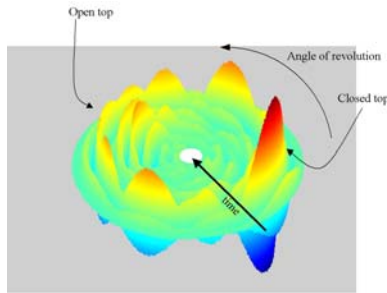

UWB backscattering of the tin dependent on the angle of revolution (above: impulse back scattering; below: normalised radar cross section). One revolution covers approximately 3200 impulse response functions

Fig. 7. Backscatter experiment with a fast rotating tin

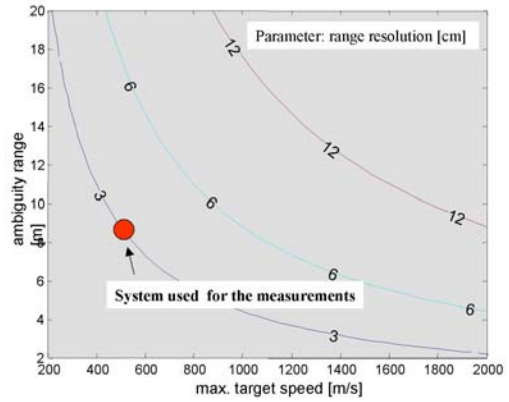

Fig. 8. Relation between max. target speed, ambiguity range and range resolution for an M-Sequence radar applying a 9 stage binary divider. The spot indicates the performance of the UWB-system used for the measurements corresponding to Fig. 7 i.e. its ambiguity range was about 8 m, the range resolution 3 cm and the maximum observable target speed about 500 m/s.

The European Project DEMINE (ESPRIT 29902) initialised the implementation of the first integrated M-Sequence Radar. The DEMINE-GPR is based on a linear array of two rows of each having 6 equidistant co-polar antennas [7]. The antennas of one row act as transmitter. The antennas of the second row receive the scattered fields.

The DEMAND-GPR also built within the frame of a European Project (IST-2000-25351) is a polarimetric linear array for vehicle based operation ([8], Fig. 5). It constitutes 15 transmitter channels and 20 receive channels. A maximum of 10 channels can receive in parallel.

A project from QinetiQ (UK) was targeted to build a multi sensor mine detector for handheld operation ([9], Fig. 6). Its GPR-part is based on a 3 by 3 UWB-array in which each antenna is used for both transmitting and receiving.

Two final examples shall demonstrate two other aspects – measurement speed and precision - of the features of the M-Sequence method.

In order to give an impression of the measurement speed which can be attained by the M-Sequence approach, the backscattering of a fast rotating hollow cylinder with one closed side (empty food can) has been measured. The tin was driven by an electric hand drill. The rotation axis was perpendicular to the cylinder axis. Due to the simplicity of the arrangement the imbalance of mass limited the number of revolutions to approximately 600 rpm (which was however not a real challenge for the measurement system). The AD-converters transferred the digitised data immediately into a high speed buffer and they were then processed off-line in a PC. Fig. 7 represents the results. The impulse response clearly indicates the differences between the backscattering at the closed and open top of the tin.

Since no other possibilities were available to test the limit of the target speed, a corresponding estimate was derived from the ambiguity function (see also (1)). It mutually relates range resolution, ambiguity range, maximum target speed and under sampling factor of the radar device. A corresponding relation is depicted in Fig. 8 for an under sampling factor of $u_{sf} = 512$ as applied in the experiment above.

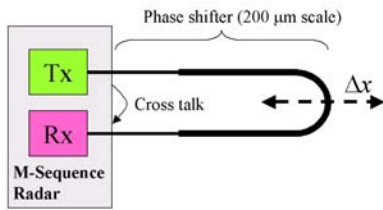

The experimental set-up: The mechanical displacement of a phase-shifter was compared with the data provided by the M-Sequence radar

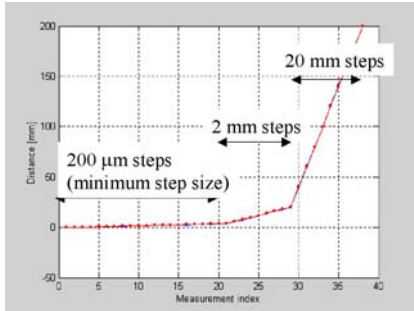

40 measurements at different distances were made and the resulting distance values were determined from the radar data. Over the first 20 measurements the total length of the phase shifter was increased in steps of 200 μm , then by 2 mm each and finally by 20 mm.

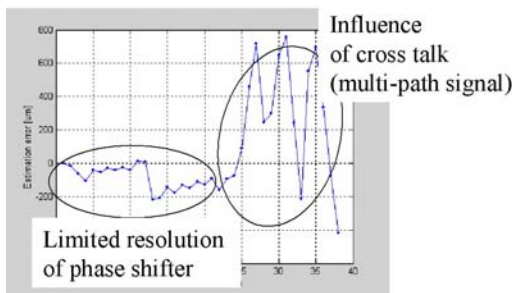

Error of the radar distance measurement

Fig. 9. Experimental verification of the distance resolution of an M-Sequence radar. The effective bandwidth of the radar device was about 4 GHz. The system was driven by a 9 GHz-DRO.

The time stability of the M-Sequence device is given by the stability of the RF-clock generator. That is, a high quality (single tone!) generator results in a stable measurement system, which can be applied for precise distance (thickness) estimations. The simple experiment corresponding to Fig. 9 demonstrates the gained resolution (see also [10]). The resulting errors were less than 200 μm for short distance variations, mainly determined by the scale resolution of the mechanical phase shifter. The increased error within the range of 800 μm at larger distance variations is due to multi-path signals (cross talk) which were not adequately respected by the data processing at this stage.

IV. CONCLUSION

The UWB approach is a promising and challenging technique for a great deal of sensor tasks for volume applications with economical and social impact. The M-Sequence technique provides stable UWB-data at reasonable costs and device dimensions due to its simplicity

and the absence of bulky off-chip components which are amenable to monolithic integration.

REFERENCES

- [1] D. Shively: Ultra-wideband Radio – The new Part 15. Microwave Journal, February 2003, Vol. 46, p. 132-46 anschauen wegen UWB-Def.
- [2] I. Oppermann, M. Hämäläinen: UWB-Introduction. Tutorial 1; International Workshop on Ultra Wideband Systems, 2-5 June, Oulu, Finland
- [3] J. Sachs, P. Peyerl: A New Principle for Sensor-Array-Application. Proceedings of 16th IEEE Instrumentation and Measurement Technology Conference, IMTC/99, Venice, Italy, May 24-26, 1999, p. 1390-1395
- [4] M. Rossberg, J. Sachs, P. Rauschenbach, P. Peyerl, K. Pressel, W. Winkler, D. Knoll: 11 GHz SiGe Circuits for Ultra Wideband Radar. Bipolar/BiCMOS Circuits and Technology Meeting BCTM-2000, 25 –26 September, Minneapolis, MN
- [5] J. Sachs, P. Peyerl: Integrated Network Analyser Module for Microwave Moisture Sensors. Proceedings of Fourth International Conference on “Electromagnetic Wave Interaction with Water and Moist Substances”, p. 165 ff., 13 – 16 May 2001, Weimar (Germany)
- [6] J. Sachs, P. Peyerl, M. Kmec, F. Tkac: Digital Ultra-Wideband-Sensor Electronics integrated in SiGe-Technology. Proceedings of 32nd European Microwave Conference, Vol. 2, p.539-42, Milan (Italy)
- [7] J. A. Ratcliffe, J. Sachs, S. Cloude, G. N. Crisp, H. Sahli, P. Peyerl, G. De Pasquale: Cost Effective Surface Penetrating Radar Device for Humanitarian Demining. EUROEM 2000 conference, UK, Edinburgh 31. May - 2. June 2000. Published in P.D. Smith, S.R. Cloude (Editor): Ultra-Wideband, Short-Pulse Electromagnetics 5, p. 275-83, Kluwer Academic/Plenum Publishers, 2002
- [8] G. Alli: presentation on Third Demining Technologies Information Forum (DTIF) Workshop on Ground Penetrating Radar in Support of Humanitarian, Demining Ispra, Italy, 23-24 September, 2002. <http://www.maic.jmu.edu/dtif/Conferences/Ispra2/papers.html>
- [9] G. Crisp: presentation on Third Demining Technologies Information Forum (DTIF) Workshop on Ground Penetrating Radar in Support of Humanitarian, Demining Ispra, Italy, 23-24 September, 2002. <http://www.maic.jmu.edu/dtif/Conferences/Ispra2/papers.html>
- [10] R. Zetik , J. Sachs, P.Peyerl: UWB Radar: Distance and Positioning Measurements. International Conference on Electromagnetics in Advanced Applications 2003, 8-12 September 2003, Torino, Italy